



Fig. 1 What is *SOVEREIGN* and Why You Should Care

1.

In 1926, an article entitled "La Maison Roulant de M. Raymond Roussel" appeared in the August issue of *Revue du Touring Club de France*. This article on the rolling home of Raymond Roussel would become the source most frequently cited by writers who attributed invention of the first mobile motor home to the French artist Raymond Roussel. It was said that amidst the popular rise of fascist ideologies between 1925 and 1926, Raymond Roussel constructed the world's first roulotte for nomadic writing. The roulotte was thirty feet long by eight feet wide and resembled a funerary caravan. Roussel would boast to his admirers that Italian prime minister Benito Mussolini visited the habitable hearse and complimented Roussel on the accomplishment. At the time of his visit to Roussel's roulotte, Mussolini was on friendly terms with the United States of America and had organized for an Ancient Roman column to be transported across the Atlantic Ocean, from seaside Ostia to lakeside Chicago. Before Roussel's suicide in Sicily in 1934, the psychiatrist Pierre Janet dedicated a case study to him. To protect Roussel's identity, Janet referred to his patient as Martial. In the case study, Janet observed that Martial had always lived and worked in the ecstatic image of his own death.

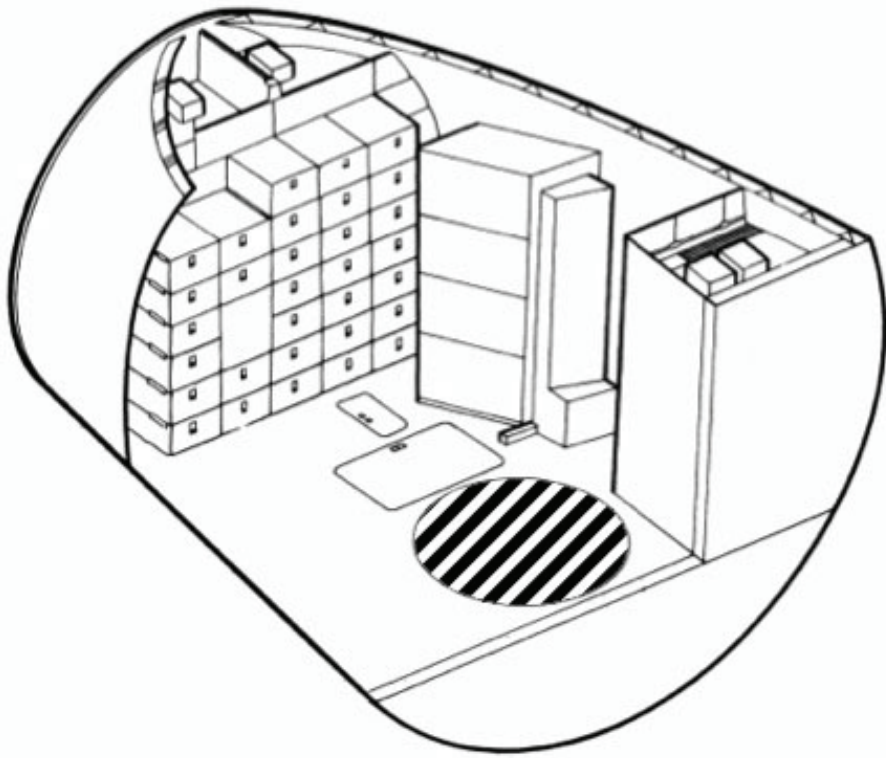

Fig. 2 Interior of a space shuttle's middeck with banks of lockers containing experiments

2.

In recent years, the influence of Raymond Roussel on contemporary artists has been the topic of a number of exhibitions organized by authoritative institutions. The art professionals involved in organizing these exhibitions have followed a trend: they both ignore Roussel's declared admiration for Mussolini while repeatedly quoting a passage from the posthumously published *How I Wrote Certain of My Books*. In this passage, Roussel claims that, though he traveled extensively, all of his works were composed from the "imagination". And yet, taking into account Roussel's clever rhetoric of self-mythologization, what he may have meant by "imagination" is not as clear as might be assumed. Indeed, reading Roussel suggests that "imagination" as Roussel intended, was a complex parodic apparatus of invention, one in which the mind submits itself to extreme contortions in order to feel itself as material, as "brain". In Roussel's travelogues, writing from death is enacted through the creative destruction of words and, respectively, the worlds that these words construct. Language pictures are twisted in sound and concept into imaginary objects: portals to a parallel universe. Roussel's plays, novels and performances are examples of the elliptical swing that rules exchange among the imaginary, the symbolic, the real and the material.

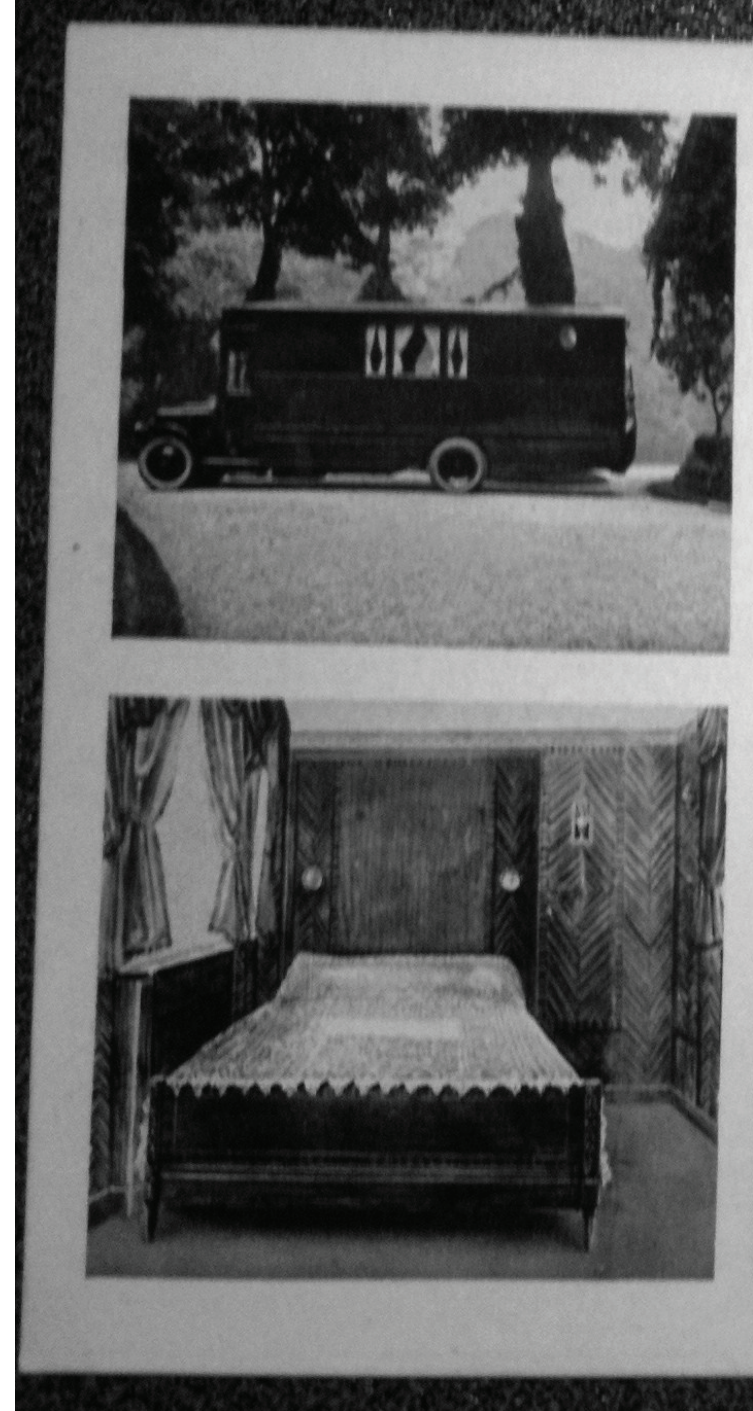
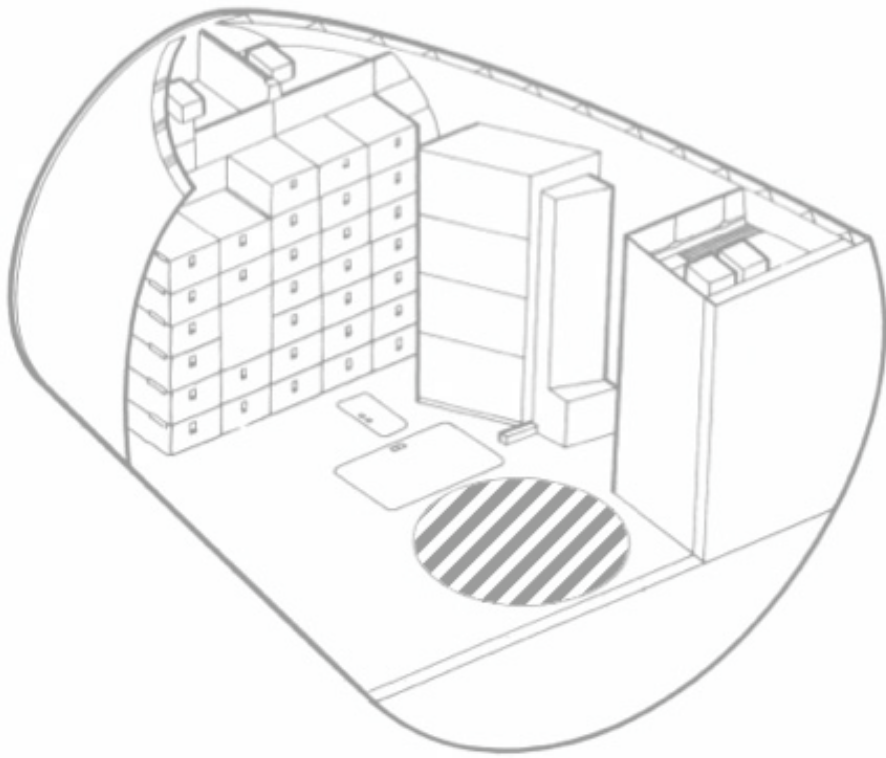

Fig. 3 Interior of Raymond Roussel's Roulotte

3.

Like the “rolling home” of Raymond Roussel, the international land yacht called model Sovereign is thirty feet long and eight feet wide. The land yacht model Sovereign was on the production line of the North American trailer company Airstream in 1973. It featured full amenities and conveniences. In 2012, a Sovereign model Airstream stripped of its full amenities and conveniences served as the base structure for the construction of *SOVEREIGN*, a nomadic writing laboratory. *SOVEREIGN* was gutted and rebuilt based on the original concept for the first North American Airstream trailer built in 1929. This trailer, created in the image of the Hindenburg airship, was invented three years after Roussel’s roulotte. The grounded airship of North American design was equipped with only a heater and an icebox as its luxuries. Created by Wally Byam, the publisher of a popular do-it-yourself magazine, plans for building the “trailer for \$100” could be acquired by anyone for the cost of a single magazine issue.

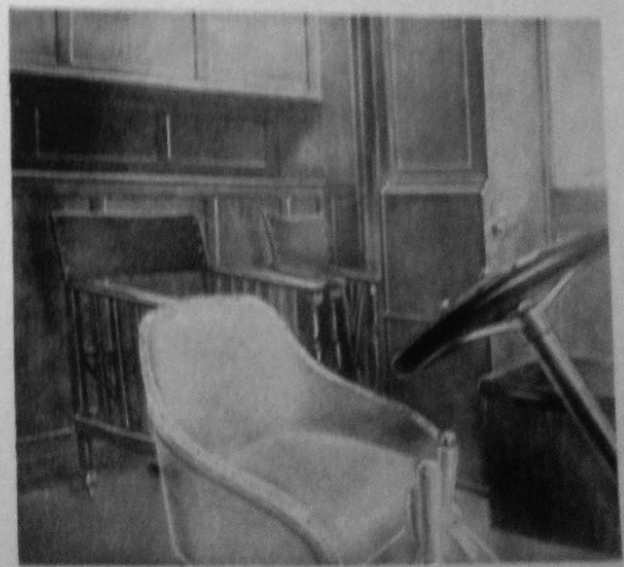
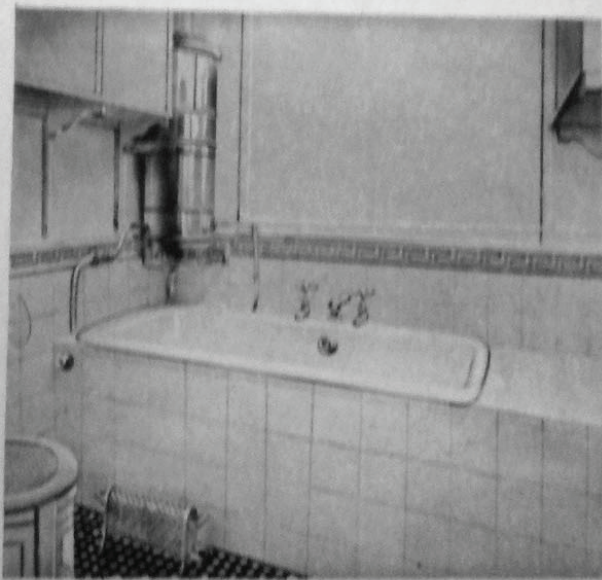
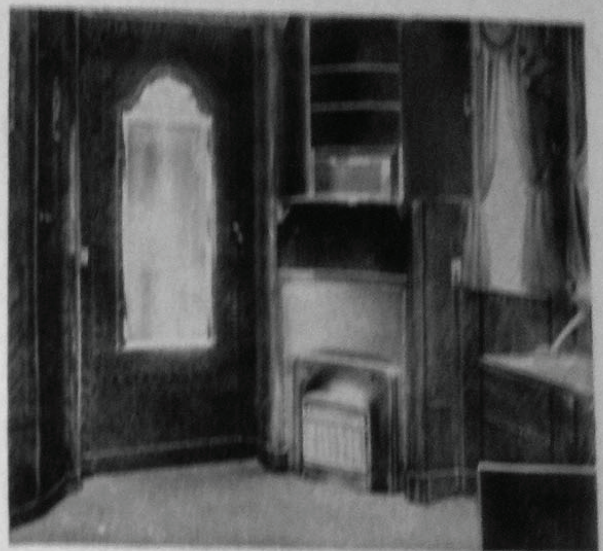
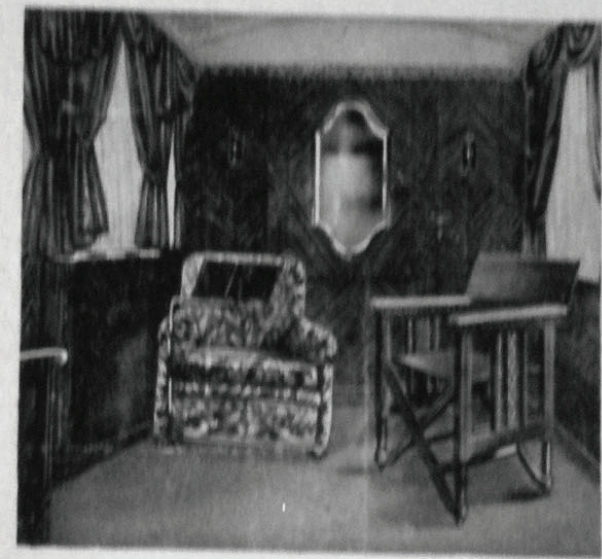

Fig. 4 Interior of Raymond Roussel's roulotte

4.

It was in the fall of 2012 that the shell of an international land yacht, model Sovereign, was purchased in New Mexico. The model Sovereign was transported through Truth and Consequences, New Mexico – past the Trinity Atomic Testing Site in White Sands – to the borderlands between West Texas and Northern Mexico. With the generous collaboration of a former Hollywood actor and a Houston musician turned borderlands-city-councilman, *SOVEREIGN* was docked in the desert off of Route 90. between the towns of Valentine and Marfa. Gutted and jerry-rigged, *SOVEREIGN* was redesigned in the borderlands tradition of making-it-by ,and in the spirit of the original 1929 land yacht concept, all of the model Sovereign's 1973 amenities were removed. With only an electric radiator, a mini-fridge and a slow cooker as its luxuries, the land yacht was fashioned into a livable desert pod. Attached to a nearby electrical line, it thus became a parodic incubator for emancipatory neuroaesthetics, a combination of desert-thinking and death-writing. Episode Two of the project RK-LOG began post-production in *SOVEREIGN*: writing, audio-editing, video-editing and online platform design were developed in solitary confinement, from the remote location of a docked land yacht in the desert of West Texas.



Fig. 5 Tags for the International Land Yacht, Model Sovereign

5.

Meanwhile, debates about surveillance technologies and the rationing of end-of-life medicalization were experiencing a synchronized increase in prominence amidst media reports. This coincidence suggested that a certain sentimental necrophilia was acting to reinforce the dominant discourses. It is important to assert that rethinking the socio-political consequences of death attitudes is not sentimental necrophilia. Thanatography, or death writing, is a form of writing from death that works through death and dying, through the processing of the dead, through the figure of the brain in relation to death. It does this to challenge all of the various representations that have so aptly naturalized the idea of the centralized State in the human body, that Statism is lived as a biologically determined truth.

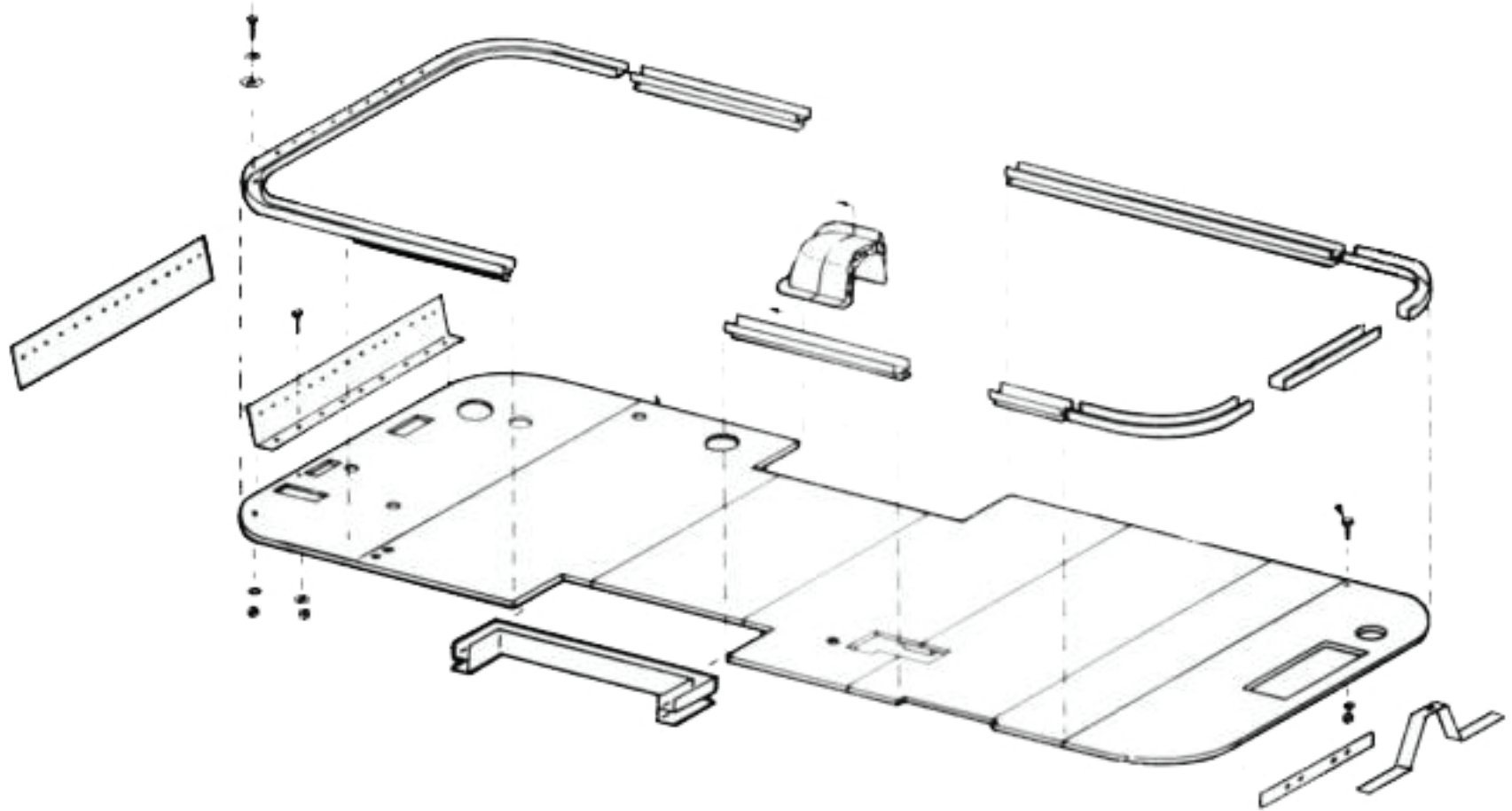

Fig. 6 Diagram of the Chassis of the Land Yacht, Model Sovereign

6.

If every cultural artifact from the toilet bowl to the bikini wax can be read as the symptom of an ideological position, then what of our ways of death, our so-called "end-of-life options"? The ongoing project RK-LOG is an experiment in poet's theater that treats the figure of the brain as an emblem of twenty-first century death attitudes. Treated as an emblem, the brain is no longer just an organ but a complex allegory of the mind. The home base for production of RK-LOG is the docked land yacht, *SOVEREIGN*. There is no better place for desert-thinking and death-writing than the borderlands between West Texas and Northern Mexico. Between Presidio County and the Chihuahua region, two cultures with drastically different death attitudes meet. Documented encounters between real individuals and the figure of a fictional character named RK are compiled to document the socio-political consequences of a collective popular imaginary that experiences the brain as material soul.